

**Recovery Of Valuable Raw Materials -
Protection Of Machines And Plants**



**Technology
Full Of
Attraction**



L 0452 e

Dimensioning notes:

Iron parts need to be in a magnetic field for at least 0.4 to 0.5 seconds in order to be magnetized and pulled out of the material flow. The size of the magnet block must be selected accordingly.

When separators are mounted across the conveyor the magnet length must be at least the width of the conveyor belt. In-line mounted magnets must be wide enough that the entire width of the belt is covered. Special designs are possible for special uses.

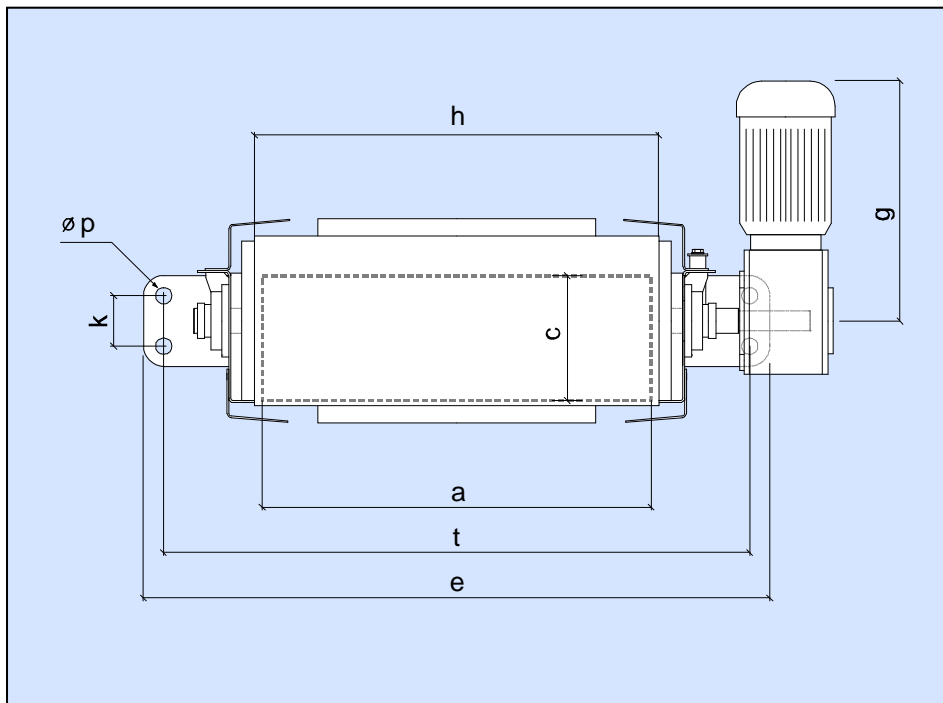

DIMENSIONS AND TECHNICAL DATA

Type	belt width mm		working distance mm	weight kg	drive kW	overall dimensions		
	across	inline				length	width	height
0452-40/50-200	500	400	120-160	440	1,5	1450	1000	600
0452-40/70-200	650	400	120-160	540	1,5	1650	1000	600
0452-40/90-200	800	400	120-160	640	1,5	1850	1000	600
0452-40/110-200	1000	400	120-160	740	1,5	2050	1000	600
0452-60/50-200	500	650	170-220	640	1,5	1450	1200	600
0452-60/70-200	650	650	170-220	780	1,5	1650	1200	600
0452-60/90-250	800	650	170-220	920	1,5	1850	1200	600
0452-60/110-250	1000	650	170-220	1060	1,5	2050	1200	600
0452-60/130-250	1200	650	170-220	1220	1,5	2250	1200	600
0452-75/70-250	650	800	220-270	1200	2,2	1925	1380	700
0452-75/90-250	800	800	220-270	1340	2,2	2125	1380	700
0452-75/110-250	1000	800	220-270	1660	2,2	2325	1380	700
0452-75/130-250	1200	800	220-270	1800	2,2	2525	1380	700
0452-75/150-250	1400	800	220-270	1940	2,2	2725	1380	700
0452-95/70-250	650	1000	240-320	1430	2,2	1975	1580	700
0452-95/90-250	800	1000	240-320	1650	2,2	2175	1580	700
0452-95/110-250	1000	1000	240-320	1870	2,2	2375	1580	700
0452-95/130-250	1200	1000	240-320	2100	2,2	2575	1580	700
0452-95/150-250	1400	1000	240-320	2330	2,2	2775	1580	700
0452-115/90-250	800	1200	260-350	2270	3,0	2175	1780	700
0452-115/110-250	1000	1200	260-350	2250	3,0	2375	1780	700
0452-115/130-250	1200	1200	260-350	2570	3,0	2575	1780	700
0452-115/150-250	1400	1200	260-350	2900	3,0	2775	1780	700
0452-130/110-250	1000	1400	280-370	2580	3,0	2375	1980	700
0452-130/130-250	1200	1400	280-370	2950	3,0	2575	1980	700
0452-130/150-250	1400	1400	280-370	3340	3,0	2775	1980	700
0452-130/170-250	1600	1400	280-370	3750	3,0	2975	1980	700
0452-150/130-250	1200	1600	300-390	3400	3,0	2575	2180	700
0452-150/150-250	1400	1600	300-390	3840	3,0	2775	2180	700
0452-150/170-250	1600	1600	300-390	4310	3,0	2975	2180	700
0452-150/190-250	1800	1600	300-390	4810	3,0	3175	2180	700

We would be more than happy to help you select the right magnet separator for your purposes. Please give us a call or send us a fax or e-mail. A corresponding data sheet that can be downloaded and filled in can be found at: www.wagner-magnete.de

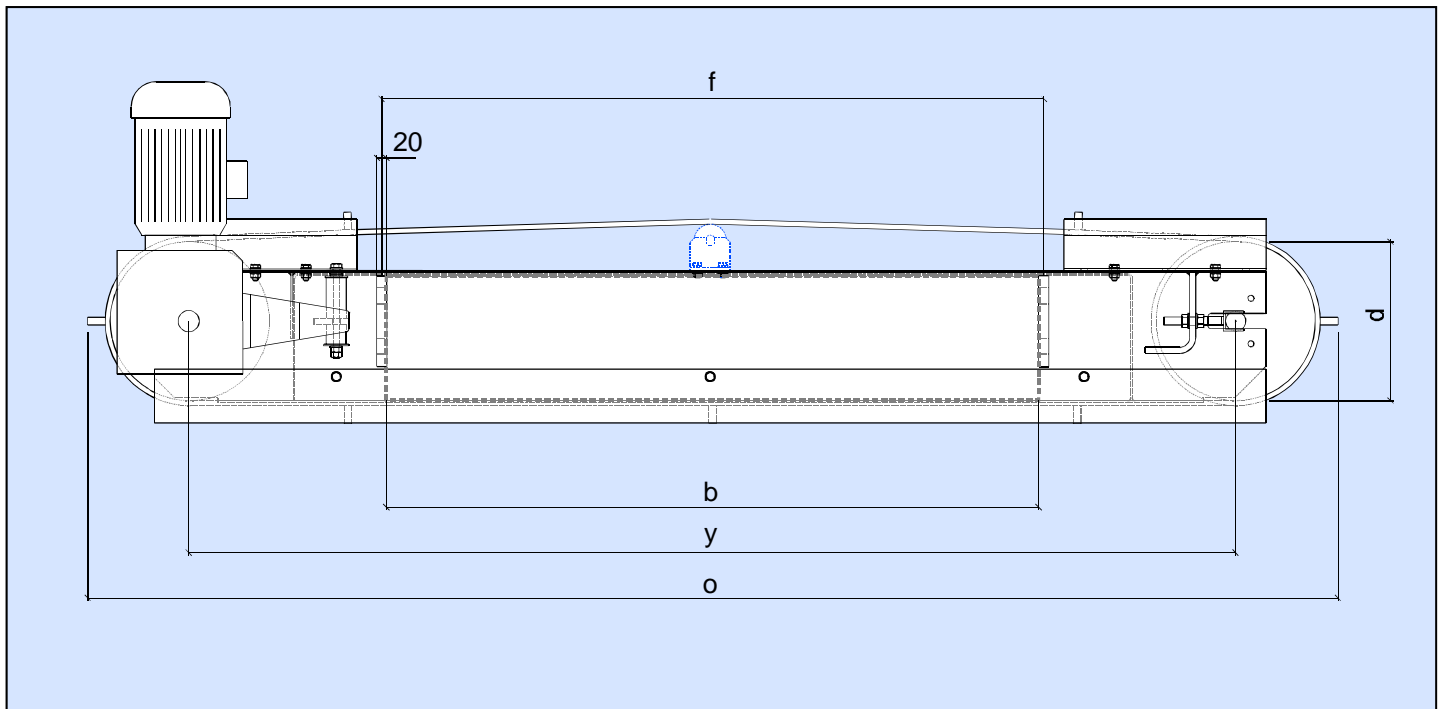

DIMENSIONS

magnet dimensions			d	e	f	g	h	k	o	p	t	y
a	b	c										
420	500	200	215	896	480	440	450	85	1450	24	838	1115
420	700	200	215	896	680	440	450	85	1650	24	838	1315
420	900	200	215	896	880	440	450	85	1850	24	838	1515
420	1100	200	215	896	1080	440	450	85	2050	24	838	1715
620	500	200	215	1046	480	440	650	85	1450	24	988	1115
620	700	200	215	1046	680	440	650	85	1650	24	988	1315
620	900	200	215	1046	880	440	650	85	1850	24	988	1515
620	1100	200	215	1046	1080	440	650	85	2050	24	988	1715
620	1300	200	215	1046	1280	440	650	85	2250	24	988	1915
770	700	250	315	1240	710	500	800	100	1925	32	1160	1470
770	900	250	315	1240	910	500	800	100	2125	32	1160	1670
770	1100	250	315	1240	1110	500	800	100	2325	32	1160	1870
770	1300	250	315	1240	1310	500	800	100	2525	32	1160	2070
770	1500	250	315	1240	1510	500	800	100	2725	32	1160	2270
970	700	250	315	1440	710	500	1000	100	1975	32	1360	1470
970	900	250	315	1440	910	500	1000	100	2175	32	1360	1670
970	1100	250	315	1440	1110	500	1000	100	2375	32	1360	1870
970	1300	250	315	1440	1310	500	1000	100	2575	32	1360	2070
970	1500	250	315	1440	1510	500	1000	100	2775	32	1360	2270
1170	900	250	315	1640	910	500	1200	100	2175	32	1560	1670
1170	1100	250	315	1640	1110	500	1200	100	2375	32	1560	1870
1170	1300	250	315	1640	1310	500	1200	100	2575	32	1560	2070
1170	1500	250	315	1640	1510	500	1200	100	2775	32	1560	2270
1320	1100	250	315	1840	1110	500	1400	100	2375	32	1760	1870
1320	1300	250	315	1840	1310	500	1400	100	2575	32	1760	2070
1320	1500	250	315	1840	1510	500	1400	100	2775	32	1760	2270
1320	1700	250	315	1840	1710	500	1400	100	2975	32	1760	2470
1520	1100	250	315	2040	1310	500	1600	100	2575	32	1960	2070
1520	1300	250	315	2040	1510	500	1600	100	2775	32	1960	2270
1520	1500	250	315	2040	1710	500	1600	100	2975	32	1960	2470
1520	1700	250	315	2040	1910	500	1600	100	3175	32	1960	2670



The non-ferrous separators can also be delivered as devices protected against explosions according to ATEX 95 (RL94/9). For additional information, please see our I Ex-1 leaflet!

L 0452 e

PERMANENT MAGNETIC BELT SEPARATOR

- + *Nonmagnetic frame*
- + *Two-pole magnetic system*
- + *Shielded magnet body*
- + *Nonmagnetic protection devices*
- + *Bearing protectors*
- + *Optimized torque bearing*

The best in the long run

The proven concept of a non-magnetic frame construction made of laser cut manganese hard steel sheet metal reliably prevents ferrous items from sticking to the magnets. The sealed magnet body is shielded over a large area and empty cavities are closed on all sides so that foreign objects cannot get into the inside of the conveyor belt area. This reduces wear and minimizes cleaning. A protective panel that extends far into the pole face protects the edges of the discharge belt and prevents ferrous items from being pulled under the belt. In general, our magnets are designed as two pole systems because they are much better than single pole systems. Compact ferrous items are attracted with a stronger force with two pole systems. Suspension equipment is not magnetized because the magnetic field only works in a downward direction.

Installation notes

The distance between a magnet and the conveyor should be as small as possible because the magnetic force decreases exponentially over distance. At the same time, it is important to make sure that the distance is at least large enough so that the studs on the discharge belt can securely remove all attracted ferrous items from the material flow. When removing items crosswise, we recommend a low trough formed conveyor belt. This improves ferrous item removal and prevents damage caused by wedging large ferrous items between the magnet and conveyor equipment. If long or bulky ferrous items are included in the material on the conveyor or the transport speed of the material on the conveyor exceeds 3 m/s, we recommend using the in-line arrangement.

Driving motor possibilities:

G1: geared motor Flender
G2: geared motor SEW
G6: geared motor NORD
H1: hydraulic drive with clutch
H3: hydraulic drive without clutch
T7: drum motor drive Van der Graaf

K: with temperature sensor

Available discharge belts:

BF: oil resistant belt
BV: improved belt
BR: belt with REMA coating
BH: heat resistant belt
BS: belt with special studs
BW: belt with 35/60 mm high studs

Special designs can be manufactured.

Accessories:

Off-track monitor
Suspension devices
Zero-speed monitor
Special protection devices
Nonmagnetic conveyor rollers

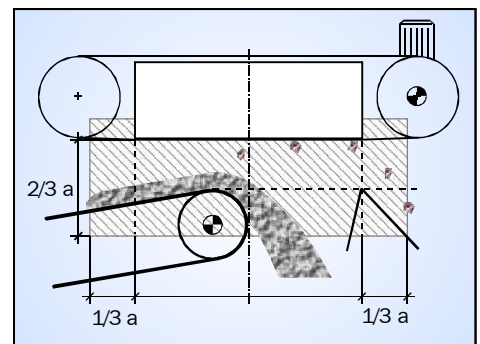
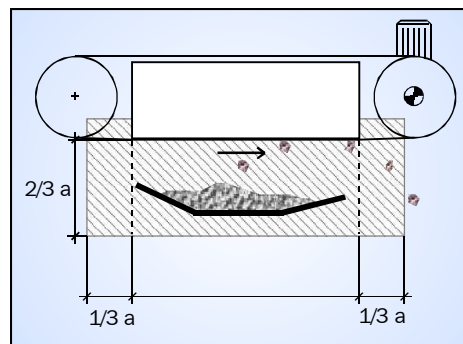
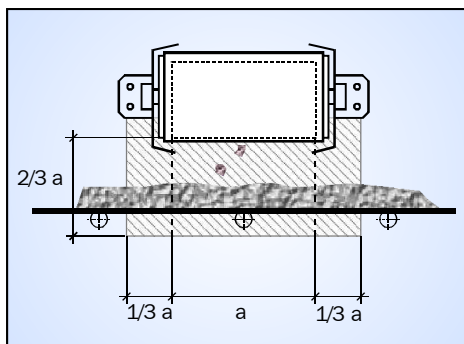

Non-magnetic area

In the hatched area, no construction parts that can be magnetized are permitted, otherwise the effectiveness of the magnets will be reduced. Carrier rollers and material guides must be removed or made of material that cannot be magnetized. When using the in-line Arrangement, the head roller must be non-magnetic

Our company has been DIN EN ISO 9001 certified since 1995. All magnet separators are manufactured and tested according to DIN VDE 0850 and correspond to CE and EMC regulations